

PRORIL

50 Hz

GOBITS Series, these grinder pumps meet the demanding needs of commercial and residential sewage applications. GOBITS series pumps employ a grinding mechanism to effectively grind and transfer solids under high pressure from one place to a higher or a distant place. Ideal for residential and low-pressure sewer applications.

Sewage Pump

GOBITS 55

Grinder Pump



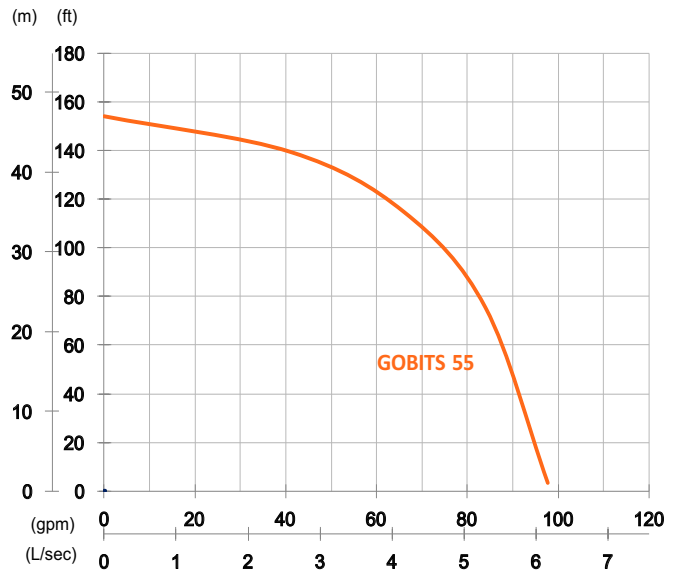

Shaft Speed : 2850 rpm

Outlet : 50mm, 2in

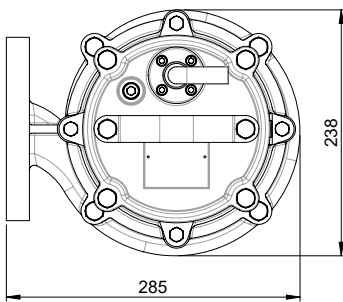

OUTPUT	HEAD	FLOW
5.5 kW	Rated : 35m, 115ft	Rated : 4.2 L/s, 66 gpm
7.5 HP	Max : 47m, 154ft	Max : 6.2 L/s, 98 gpm

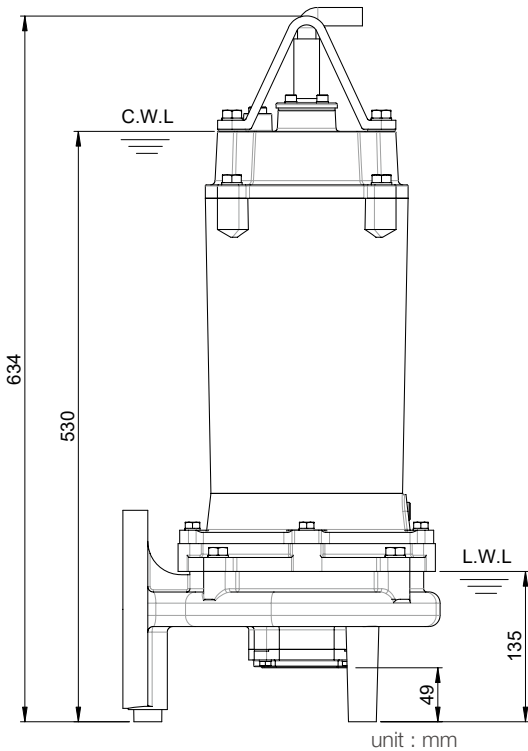

Weight : 61kg / 135 lbs

Pump Type	Electric Submersible Pumps	
	3-Phase	
Motor	Type	Induction Motor
	Poles	2 Pole
	Insulation	Class F
	Protector	Circle Thermal Protector
	Starter	D.O.L.
Lubricant	Food Grade (ISO VG32)	
Impeller Type	Vortex	
Shaft Seal	Double Mechanical Seal	
	Silicon Carbide VS Ceramic / Carbon	
Bearings	C3 Shielded ball bearings	
Cable	PVC (CSA Certified) / H07RN-F	
	10m (33ft) or longer upon request.	
Materials	Pump Casing	Gray Iron
	Impeller	Gray Iron
	Motor Frame	Gray Iron
	Motor Shaft	Stainless Steel
	Grinder Set	Chromium Iron
Max. Liquid Temperature	40°C (104°F)	
Max. Submersion Depth	20m (66ft)	
pH Range	pH 5 - pH 8	
Guide Rail	GRG-02	